

Channeltron[®]

ELECTRON MULTIPLIERS



**HIGHEST DYNAMIC RANGE TO ASSURE AN
ABSOLUTELY LINEAR RESPONSE BEYOND THE
LIMITS OF MOST ANALYTICAL INSTRUMENTS**

PHOTONIS



Whether it be environmental monitoring, developing new battery technologies, water quality assurance, ensuring the safety of our medicine or monitoring our health – accurate, sensitive, and reliable quantification is the cornerstone of modern analytical science.

Environmental scientists use Mass Spectrometry (MS) to protect and monitor our water and environment from persistent organic pollutants and polyfluoroalkyl substances (PFAS), ensuring a clean environment and safe drinking water. In the field of food safety tandem quadrupole (TQ) MS is used to protect against toxins such as mycotoxins and mold.

Pharmaceutical researchers and manufactures rely on TQ-MS to discover new treatments and ensure the medicines we take are free from toxins such as nitrosamines. Semiconductor manufacturers rely on residual gas analyzers to monitor their processes and keep their cleanrooms free of contaminants.

Critical to the success of these researchers is the performance of the detector in terms of sensitivity, dynamic range, reproducibility, and instrument uptime. These attributes allow methodologies to be rapid,

cost effective, and transferable between laboratories, meeting the exact needs of trace detection while maximizing efficiency of operation.

Quadrupole MS, using either direct analysis or coupled to chromatography, has become the technology of choice for high sensitivity analyte detection, due to its specificity, selectivity, and sensitivity.

Channeltron® Detection is at the heart of the leading manufactures' state-of-the-art mass spectrometers. Photonis Scientific is the leader in electron multiplier detection technology. This is because they offer the highest dynamic range to assure a linear response beyond the limits of most analytical instruments, longer life for greater operational up-time, low ion feedback reducing background noise, and outstanding single ion sensitivity coupled with less than 1 count/sec noise to enable sensitivity for the most challenging assays.

WHAT MAKES PHOTONIS YOUR PREFERRED PARTNER

WE KNOW THAT EXCELLENCE IN RESEARCH AND DEVELOPMENT NOT ONLY MEANS THE MOST SENSITIVE AND REPRODUCIBLE DETECTORS, IT ALSO ENSURES MAXIMUM LIFETIME AND RELIABILITY FOR YOUR CUSTOMERS, REDUCING SERVICING NEEDS AND ENHANCING THE REPUTATION OF YOUR PRODUCTS.



THE PHOTONIS DIFFERENCE

Our philosophy is to be a trusted technology partner in your R&D process; listening, collaborating, designing and manufacturing to the highest standard, truly outstanding, world-leading detection solutions. Whether that be for portable mass spectrometers where reliability and robustness is key, or cutting-edge laboratory instruments for your customers' most demanding application. The researchers, technology experts, and scientists at Photonis are dedicated to working with your research, product, and technology teams to create a specialized solution for your desired application.

RESEARCH TO MANUFACTURING, WE CONTROL THE WHOLE PROCESS

Making the ideal detector does not end with the R&D and design process. The highest quality manufacturing is equally important to the performance of the end product. Our in-house manufacturing facility ensures the seamless transfer of your ideas, specifications, and requirements from R&D to finished product. Unique amongst the industry, we control the process from beginning to end.

MANUFACTURING PROCESS

Melt lead silicate glass from raw powder in house

Extrude glass into tubes

Redraw tubes into glass sticks

Bend/shape/form sticks as necessary

Chemically and thermally treat to achieve resistive surface layer

Remove resistive layer on outside to limit current flow to inside and create internal bias resistor (if needed)

Electrode addition for ease of connection

Assemble – anything from s trap leads and anodes to fully mounted units

Test 100% for gain, noise, strip current, and other custom tests as needed

Inspect and package

PHOTONIS
Reveal the invisible

HOW DOES A CHANNELTRON® WORK?

- 1 SECONDARY ELECTRONS
- 2 SECONDARY EMISSIVE LAYER
- 3 INCIDENT IONS OR PHOTONS

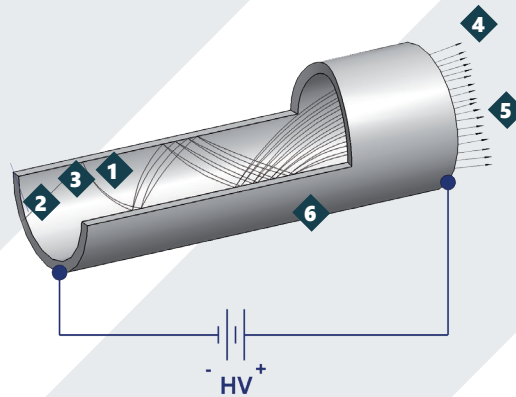

- 4 ELECTRODING
- 5 OUTPUT ELECTRONS
- 6 CHANNEL WALL



WHY PHOTONIS?

Whether the need for a detector with superior sensitivity, a wider range of spatial or temporal resolution, or the ability to detect both positive and negative ions, Photonis is able to provide either a standard or customized offer. Photonis offers a wide range of patented ion transport solutions that can increase ion throughput up to 1000X when compared to traditional solutions.

MINIATURE CHANNELTRON® ELECTRON MULTIPLIER

The Miniature Channeltron® detector is designed for use in portable analog or pulse-counting applications such as leak detectors, portable mass spectrometers, and sensors for environmental and industrial use. With a gain greater than 10 million and reduced noise, these are the ideal solution to critical detection applications.



SPIRALTRON™ HIGH PRESSURE ELECTRON MULTIPLIER

The Spiraltron™ detector delivers high performance at pressures up to 10-2 torr. Its small, compact, linear design enables longer detector life and higher dynamic range in a wide array of analytical instruments.



MEGASPIRALTRON™ COMPACT ELECTRON MULTIPLIER

The MegaSpiraltron™ detector is a physically small, robust ion detector that can achieve high gain while maintaining low noise. MegaSpiraltron™ uses six-channel spiral technology to operate at the highest pressure of any of our detectors at 1×10^{-3} . With extended dynamic range and enhanced sensitivity, MegaSpiraltron™ technology is ideal for high pressure environments such as portable mass spectrometers.



MAGNUM™ CARTRIDGE ELECTRON MULTIPLIER

MAGNUM™ detectors provide high dynamic range with high gain and low noise — available in analog or pulse counting applications. Similar to other Channeltron® products, the MAGNUM™ family of electron multipliers is also based on six-channel technology, increasing secondary electron generation and increasing linear output.



DISCOVER ION & ELECTRON DETECTION

EXPOSE EVERY DETAIL WITH PHOTONIS

Only by controlling the process from beginning to end, employing rigorous QC checks throughout the process, and through performance testing, can you achieve the highest quality channel electron multiplier detection.



Our advanced designs provide the highest sensitivity through superior signal collection and noise reduction. Available in various shapes, sizes, and voltages, Photonis' Channeltron® electron multipliers are engineered to deliver the highest performance on the market. Cones, grids, coatings, collectors and leads can all be specified, or you can choose one of our many standard models. Improvements in conversion dynode technology have resulted in structures capable of operation at higher voltages and materials with improved ion-to-electron conversion yields for better sensitivity at higher masses.

More than half of the world's mass spectrometer manufacturers rely on Photonis' Channeltron® detectors to improve the reliability of their instruments. Due to their low mass and high gain, Channeltron® electron multipliers are also used in many nuclear physics labs and space applications to count electrons and charged particles in pulse mode operation. Other applications include residual gas analysis, plasma analysis, Auger, electron spectrometers, SEM, FIB and leak detectors.

KEY FEATURES

- ◆ Longer life
- ◆ Higher dynamic range
- ◆ Reduced ion feedback
- ◆ Noise less than 1 count/second
- ◆ Excellent single ion sensitivity

LEADING YOU TO PEAK PERFORMANCE

PHOTONIS
Reveal the invisible



photonis.com | ultimatedetection@photonis.com | [in](#) [t](#) [f](#) [v](#)

© PHOTONIS. The information furnished is believed to be accurate and reliable, but is not guaranteed and is subject to change without notice. No liability is assumed by PHOTONIS for its use. Performance data represents typical characteristics as individual product performance may vary. Customers should verify that they have the most current PHOTONIS product information before placing orders. No claims or warranties are made as to the application of PHOTONIS products. Pictures may not be considered as contractually binding. This document may not be reproduced, in whole or in part, without the prior written consent of PHOTONIS.